



More information on the website
radwag.com/en/info,w1,Y6S

WLC 0.6/A1/C/2 Precision Balance



WLC 0.6/A1/C/2 Precision Balance

The drawings, photos and graphics used are for illustrative purposes only.

Functions



Plus/Minus Control



Percent Weighing



Totalizing



Parts counting



Internal battery



Peak hold



Newton unit
measurement



Under-pan weighing

Datasheet

WLC 0.6/A1/C/2 Precision Balance WL-217-0006	
Metrological parameters	
Maximum capacity [Max]	0,6 kg
Minimum load	0,5 g
Readability [d]	0,01 g
Verification unit [e]	0,1 g
Tare range	-0,6 kg
Repeatability	0,015 g
Linearity	±0,02 g
Stabilization time	3 s
Adjustment	internal (automatic)
OIML Class	II
Physical parameters	
Leveling system	manual
Display	4,3" LCD (backlit)
Weighing pan dimensions	128×128 mm
Packaging dimensions W x D x H	430×270×190 mm
Net weight	2,3 kg
Gross weight	3,5 kg
Construction	
Protection class	IP 43
Communication interface	
Communication interface	2×RS232, USB-A, USB-B
Electrical parameters	
Power supply	Adapter: 100 – 240V AC 50/60Hz 0,6A; 12V DC 1,2A Balance: 10 – 15VDC 0,6A max
Operation time on batteries	15 h (average time)
Environmental conditions	
Operating temperature	+15 – +30 °C
Relative humidity	10% – 85% RH no condensation

Repeatability is expressed as a standard deviation from 10 weighing cycles. Stabilization time depends on the ambient conditions and the dynamics of weighing pan loading; specified for FAST profile.



Additional fee for verification



Accessories (Additional Fee)

Balance Storage Case
Antivibration Tables
Power Adapters
RS 232 cables (scale - printer)
Cigarette lighter receptacle power supply cables
Under-pan weighing
RS 232, RS 485 cables

Draft Shield
RS 232 – Ethernet Converter
Displays
Receipt Printer
Protective cover for balances
RS 232 – RS 485 Converter

Software (Additional Fee)

RAD-KEY

Alibi Reader

Device dimensions W x D x H

WLC 0.6/A1/C/2 Precision Balance

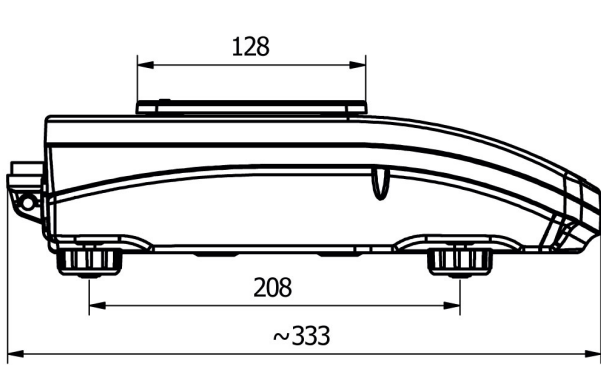

WLC A1

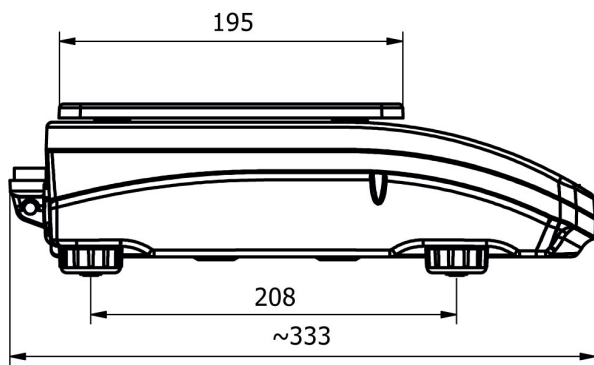
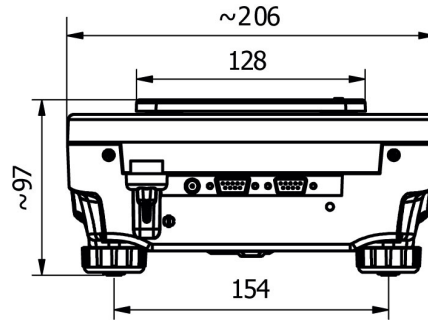

WLC A2

